

FT2A

Local Electronics, Inline with NPT Ends

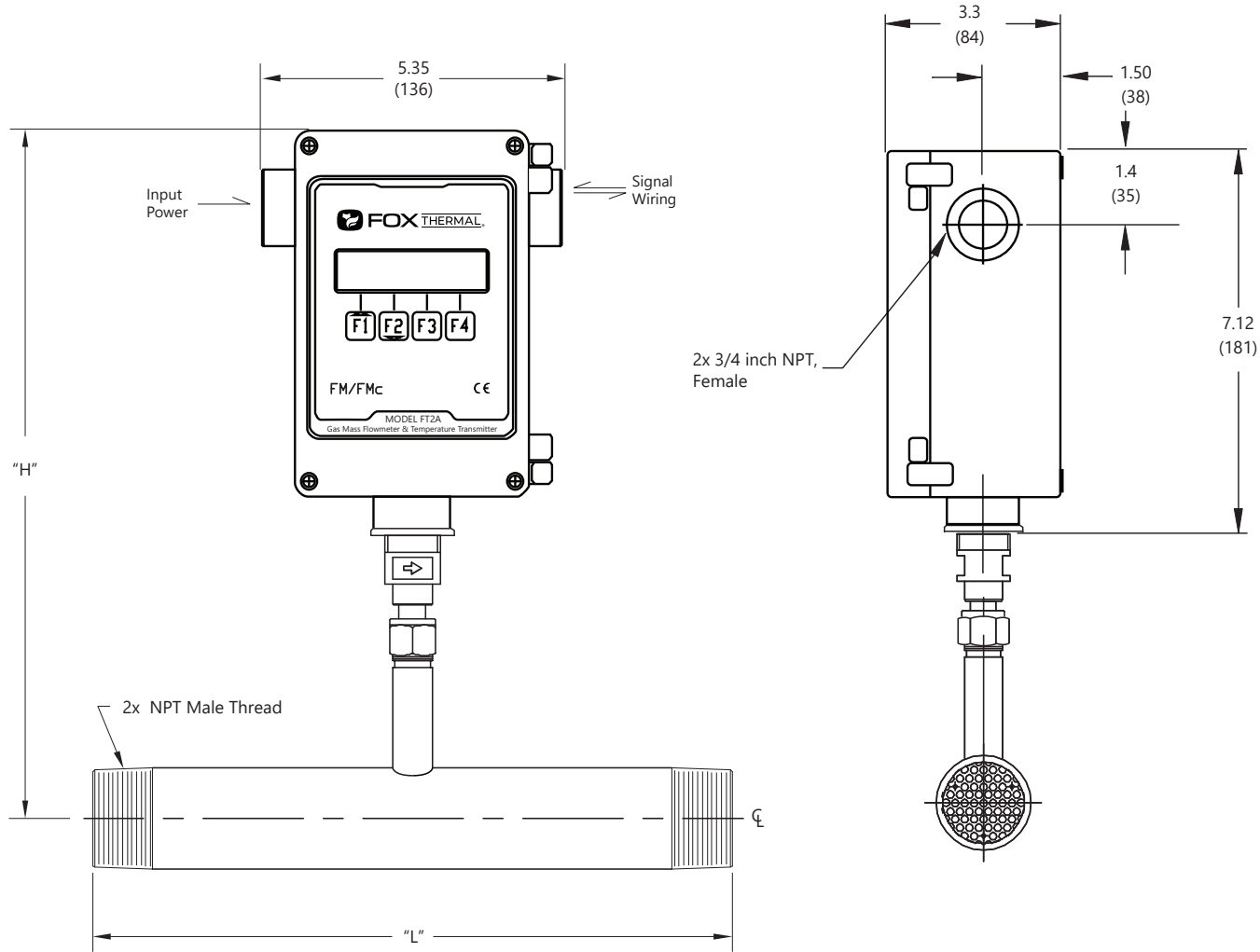

Model FT2A Dimensions			
Model Code	Body Size	Dimension "L"	Dimension "H"
025P	0.25"	5.8"	12.5" (318mm)
05P	0.50"	12"	12.5" (318mm)
075P	0.75"	12"	12.5" (318mm)
10P	1.00"	12"	12.5" (318mm)
125P	1.25"	12"	12.5" (318mm)
15P	1.50"	12"	12.5" (318mm)
20P*	2.00"	12"	12.5" (318mm)
25P*	2.50"	18"	12.6" (320mm)
30P*	3.00"	18"	14.5" (368mm)

*available in A106 Grade B Carbon steel pipe (20PC, 25PC, & 30PC)

