

# FC20 Installation Instructions for Insertion Meters



## For use with all insertion Fox Thermal Flow Meters

**Definition:** The FC20 is a flow conditioner installed upstream of a Fox Thermal flow meter that corrects irregular flow profiles to ensure flow measurement accuracy. The FC20 is installed between two flanges in schedule 40 pipe with insertion style meters.

**Purpose:** This procedure describes proper installation of the FC20 to ensure flow measurement accuracy.

### Directions:

1. Determine the correct distance for dimensions 2D and 5D from the table below for the appropriate schedule 40 pipe.
2. Ensure proper installation of the branch outlet for the flow meter. See Fox Document 107590 for more information.

Figure 1.1: FC20 Minimum Straight Run Requirements

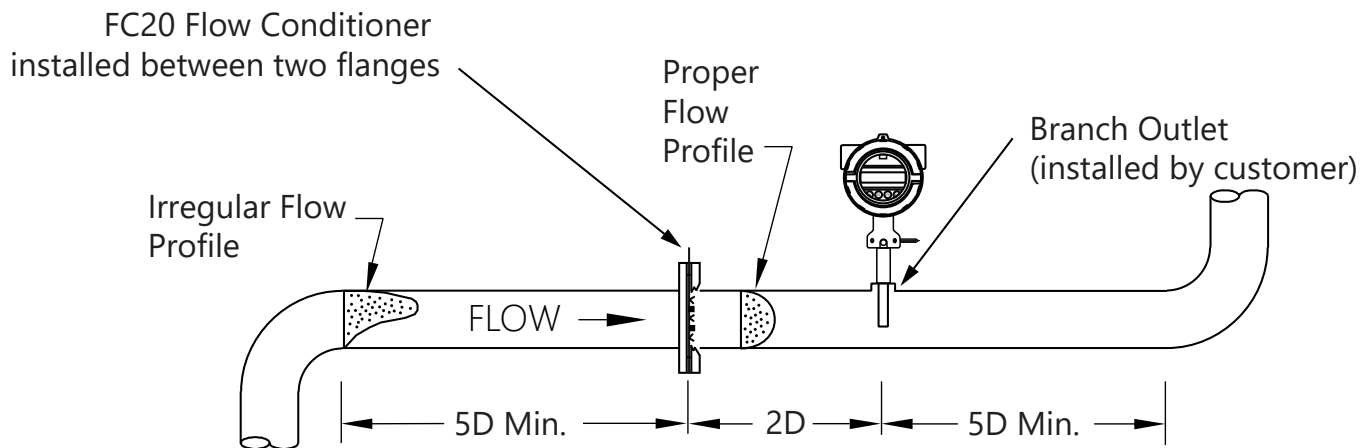

Schedule 40 Pipe Size	2D Inch (mm)	5D Min. Up/Down-stream Inch (mm)	Schedule 40 Pipe Size	2D Inch (mm)	5D Min. Up/Down-stream Inch (mm)
1.5	3.22 (82)	8 (203)	8	15.96 (405)	40 (1016)
2	4.14 (105)	10 (254)	10	20.04 (509)	50 (1270)
2.5	4.94 (125)	12 (305)	12	23.88 (607)	60 (1524)
3	6.14 (156)	15 (381)	14	26.24 (666)	66 (1676)
4	8.06 (205)	20 (508)	16	30.00 (762)	75 (1905)
6	12.13 (308)	30 (762)	18	33.75 (857)	84 (2133)

**Note:** Flow meters that will utilize the FC20 as part of the installation must be identified at time of order and calibrated with a FC20.

Figure 1.2: Upstream Side of the FC20 Flow Conditioner

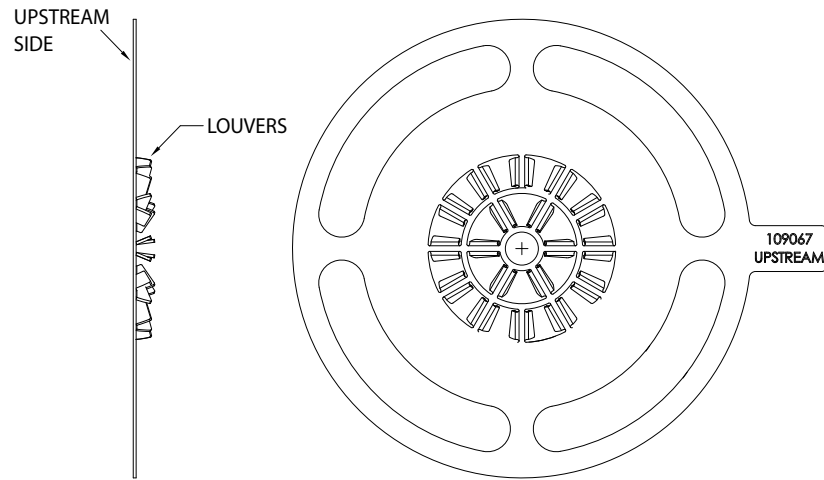

3. Position the FC20 Flow Conditioner correctly between the flanges.
  - The FC20 must be installed between flanges and two gaskets for optimum seal.
  - Center the flow conditioner between the flanges.
  - The FC20 is equipped with an orientation marker. This marker must be aligned in parallel with the probe of the flow meter.
  - The Orientation marker is also etched with "UPSTREAM" to indicate which side, or face, of the FC20 must be facing upstream. When installed correctly, the louvers inside the pipe will point downstream.

Figure 1.3: Orientation of FC20 Flow Conditioner

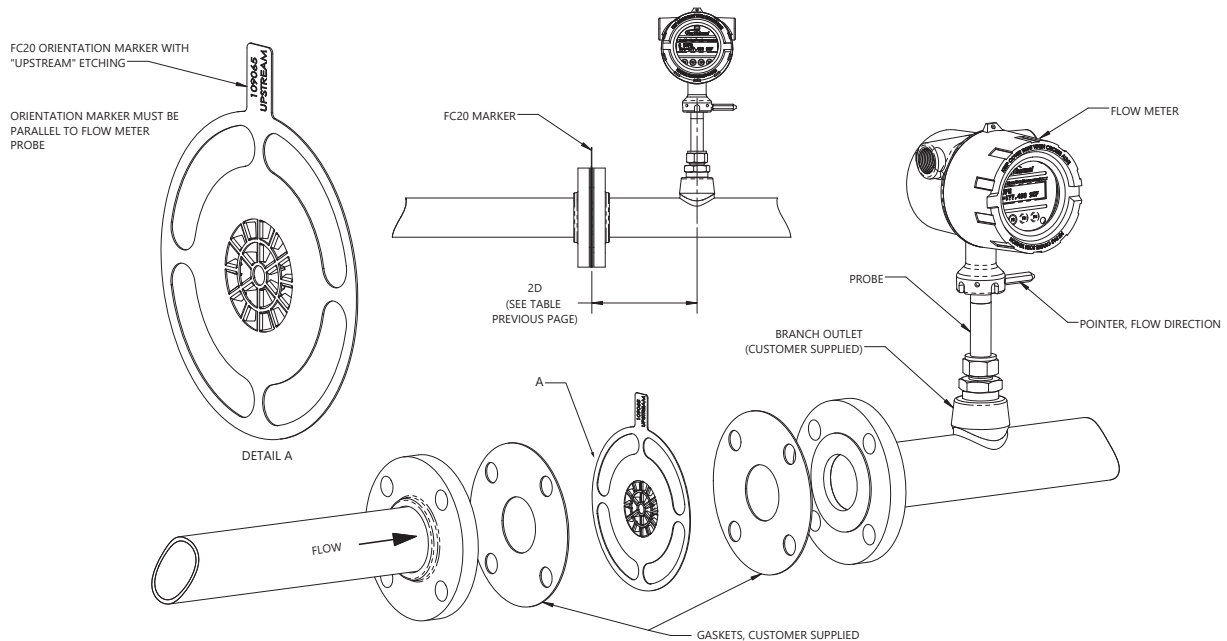

4. Tighten bolts on the flanges to complete installation of the FC20.