

Model FT1 Flowmeter Dimensional Drawing

Local Electronics, Inline Style, With 150lb Flanges

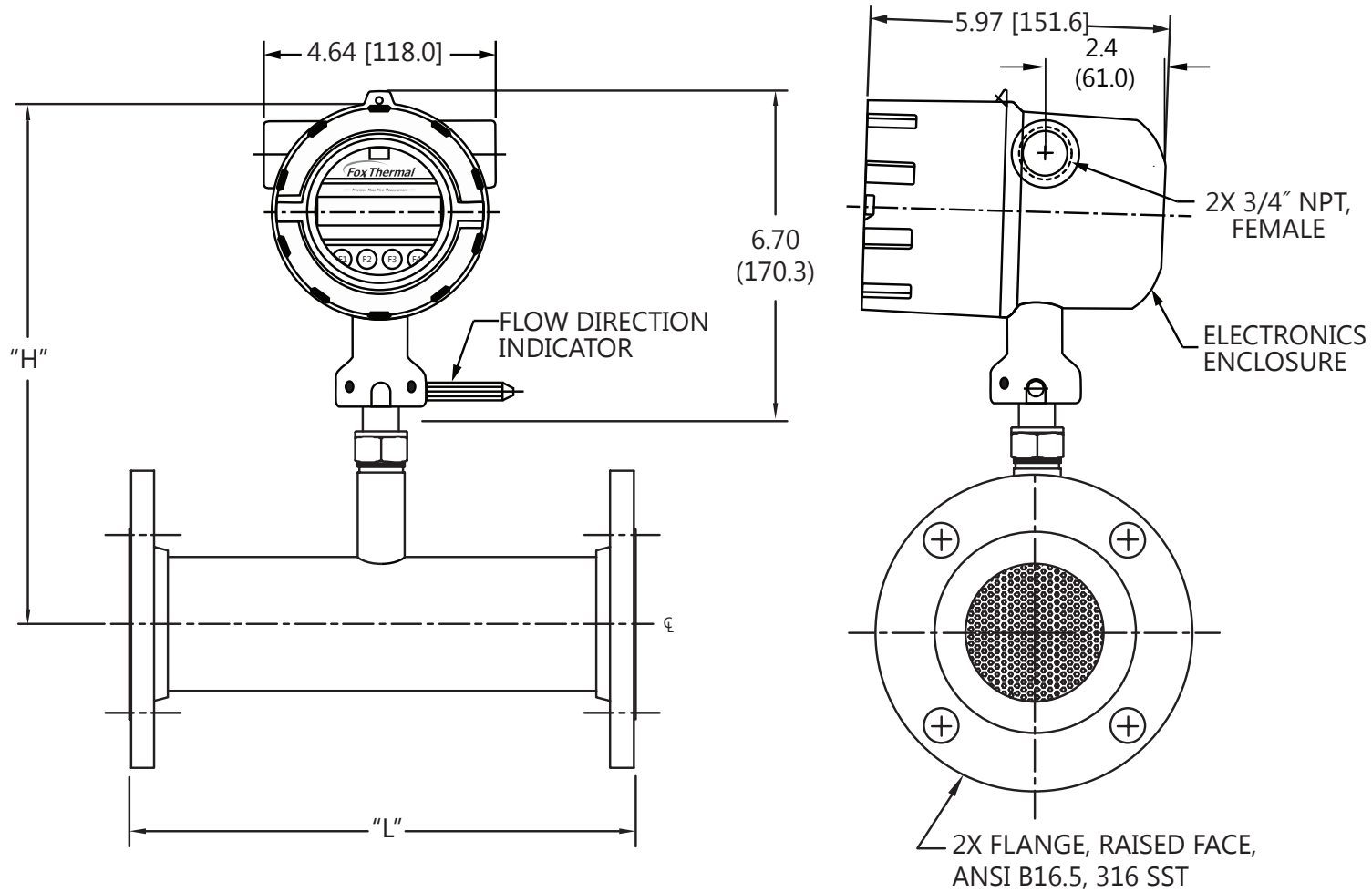

Model FT1 Dimensions			
Model Code	Body Size	Dimension "L"	Dimension "H"
075F*	0.75"	12"	10.7" (271.8mm)
10F*	1.00"	12"	10.7" (271.8mm)
125F*	1.25"	12"	10.7" (271.8mm)
15F*	1.50"	12"	12.7" (322.6mm)
20F**	2.00"	12"	12.7" (322.6mm)
25F**	2.50"	18"	12.7" (322.6mm)
30F**	3.00"	18"	12.7" (322.6mm)
40F**	4.00"	18"	12.7" (322.6mm)
60F**	6.00"	24"	12.7" (322.6mm)

*available in 316 SS only

**available in 316 SS or A106 Grade B Carbon steel pipe + A105 Flanges



399 Reservation Rd
Marina, CA 93933 USA
(831) 384-4300
www.foxthermal.com